

TYPICAL SECTION "A"

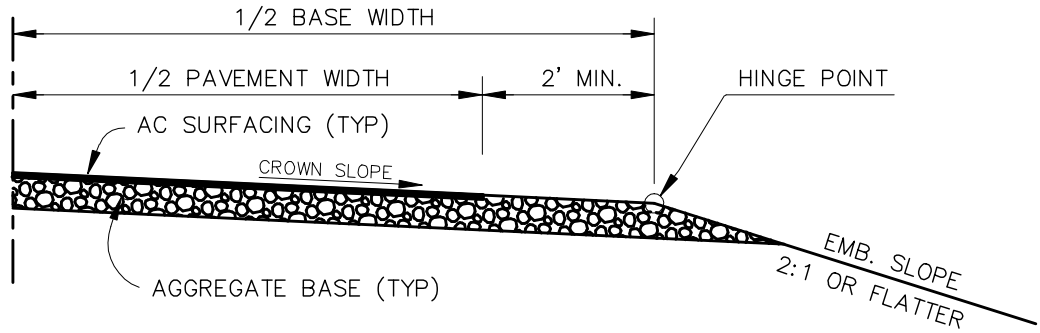

TYPICAL SECTION "B"

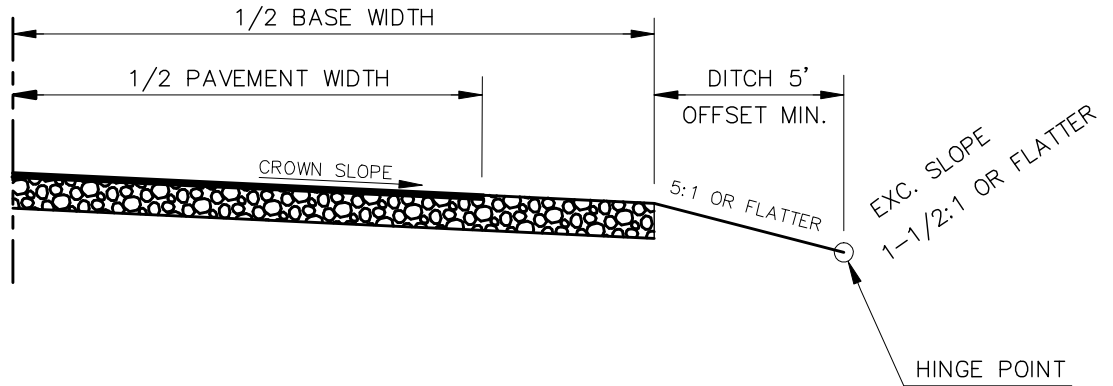

TYPICAL SECTION "C"

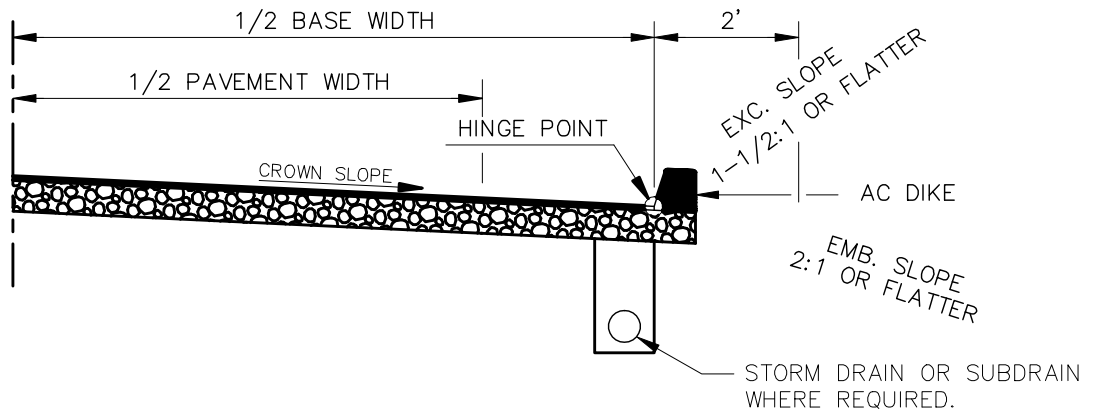

TYPICAL SECTION "D"

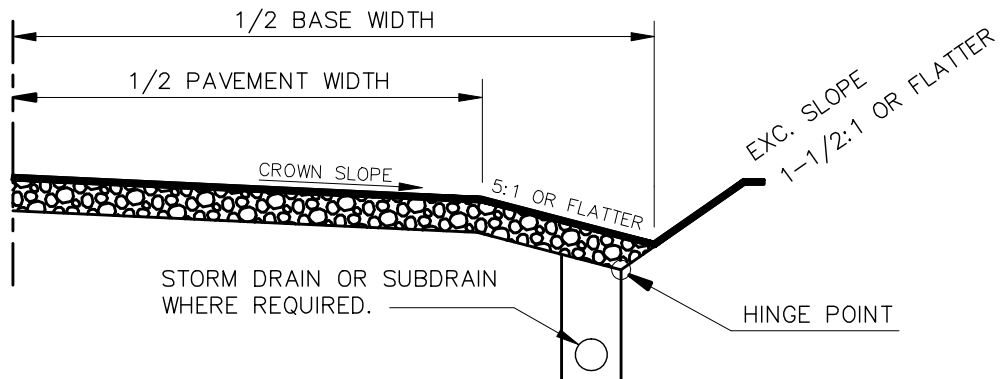

RURAL ROAD GRADING SECTIONS

MENDOT
STD. NO.
A18