

TYPE "A"

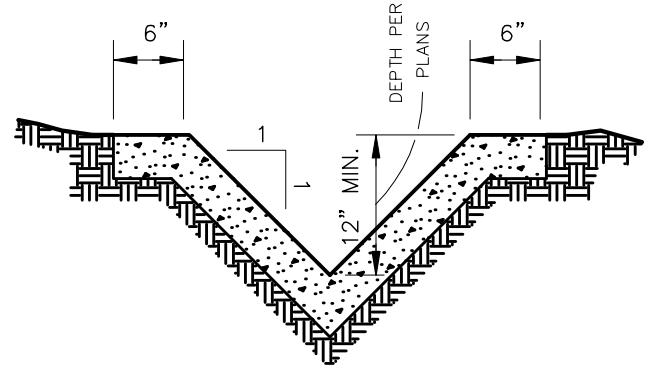

TYPE "B"

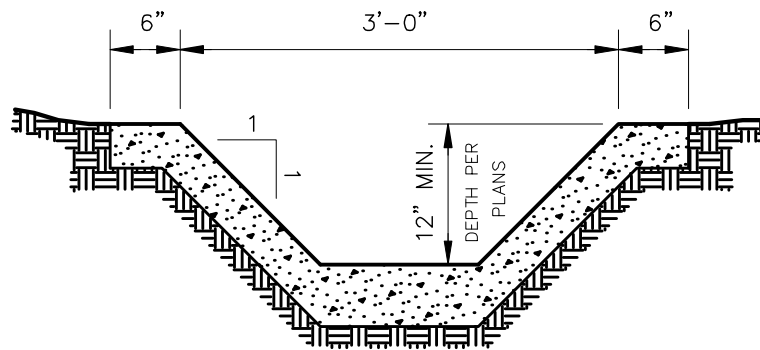

TYPE "C"

**NOTE:**

1. ALL SECTIONS SHALL BE AT LEAST 4" THICK.
2. CONCRETE SHALL BE CLASS "2" (5 SACK). REINFORCING, #4 AT 24" O.C. EACH WAY, SHALL BE PROVIDED.
3. BOTH SIDES OF THE DITCH SHALL BE FORMED WITH 2"x4" LUMBER, UNLESS OTHERWISE SHOWN ON PLANS.
4. CONCRETE FINISH SHALL BE ORDINARY SURFACE FINISH PER SECTION 51-1.18A OF THE CALTRANS STANDARD SPECIFICATIONS.
5. DITCH SIDES SHALL BE BACKFILLED AND COMPACTED IMMEDIATELY AFTER THE REMOVAL OF SIDE FORMS.
6. NO CONCRETE SHALL BE PLACED PRIOR TO FORM INSPECTION BY THE DOT INSPECTOR.
7. NO DITCH IS TO BE CONSTRUCTED ON FILLED GROUND PRIOR TO CERTIFICATION OF THE FILL TO THE DOT BY THE SOIL ENGINEER.
8. NO EXPANSION JOINTS SHALL BE REQUIRED.
9. CONCRETE-LINED DITCHES SHALL ONLY BE USED OUTSIDE OF THE ROADWAY CLEAR ZONE.



**DITCHES, CONCRETE LINED**

MENDOT  
STD. NO.  
**D61**